

| "H" HEIGHT | "W" WIDTH | 10W | 15W | 20W | 25W | 30W | 35W | 40W | 45W | 50W | 55W | 60W |
|---------------|--------------|-----|--------|--------|--------|--------|--------|--------|---------|---------|---------|---------|
| | | | 26.00" | 39.56" | 51.56" | 65.13" | 70.13" | 90.69" | 102.56" | 116.25" | 128.69" | 142.25" |

| ITEM | HEIGHT | WIDTH | DEPTH | QTY REQ'D |
|------|--------|-------|--------|-----------|
| 1 | | | | |
| 2 | | | | |
| 3 | | | | |
| 4 | | | | |
| 5 | | | | |
| 6 | | | | |
| EX. | 20H | 20W | 27.00" | 3 |

| REV | ECN # | DESCRIPTION | BY | DATE |
|-----|-------|-------------|----|------|
|-----|-------|-------------|----|------|

SIZE CODE:
05 REPRESENTS A HALF SIZE OR 12" FILTER
10 REPRESENTS A FULL SIZE OR 24" FILTER
20H15W EXAMPLE:
20H = (2) 24" FILTER HIGH
15W = (1) 24" FILTER & (1)12" FILTER WIDE

PREFILTER SIZE

- 2" (NOM.)
- 4" (NOM.)

MATERIAL

- GALVANIZED STEEL
- T-304 STAINLESS STEEL

INSULATION TYPE

- NONE
- 1" DOOR ONLY
- 1" DOOR AND HOUSING

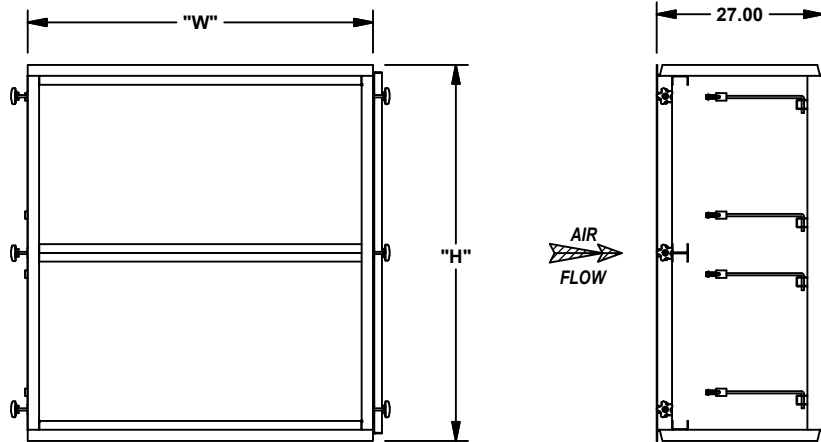

FRONT VIEW

SIDE VIEW

GAGES

- NONE
- PRESSURE
- PRESSURE W/ TRANSMITTER

LOCATION

- PREFILTER (0-2")
- FINAL FILTER (0-5")
- OVERALL (0-8")

MOUNTING

- FACTORY MOUNTED
- SHIP LOOSE

STANDARD SPECIFICATIONS:

1. UNIT SHALL BE MANUFACTURED FROM 14 GA MATERIAL.
2. HOUSING IS CONSTRUCTED WITH TWO ACCESS DOORS THAT SHALL BE HINGED/REMOVABLE AND SHALL HAVE CONTINUOUS NEOPRENE GASKETING ON THE PERIMETER. THEY SHALL BE EQUIPPED WITH POSITIVE PRESSURE ADJUSTABLE LATCHES WITH EASY GRIP KNOBS.
3. THE PREFILTER FILTER TRACKS SHALL INCORPORATE A PILE GASKET TO ENSURE SEALING OF THE FILTER TO THE TRACK.
4. EACH HEPA FILTER SHALL BE SECURED IN PLACE WITH FOUR SPRING-LOADED SWING-ARM ASSEMBLIES TO PROVIDE POSITIVE SEALING OF THE HEPA FILTER TO THE MOUNTING SURFACE.

| | | | | | |
|---|------------|---|-----------------|--------------------|---------------|
| CUSTOMER APPROVAL DRAWINGS MUST BE SIGNED IN ORDER TO PROCEED WITH PRODUCTION. [] APPROVED [] APPROVED AS NOTED [] NOT APPROVED | | | | | |
| SIGNATURE: _____ | | DATE: _____ | | | |
| COMMENTS: _____ | | | | | |
| QUOTE NO.: _____ | | | | | |
| UNLESS OTHERWISE SPECIFIED DIMENSIONS ARE IN INCHES TOLERANCES ARE: | |  | | | |
| FRACTIONS X/X ±1/8 DECIMALS X.XX ±0.13 DIAGONALS ±1/8 | | TITLE: SURELOCK-B SIDE ACCESS FILTER HOUSING | | | |
| DRAWN BY CTD | CHECKED BY | APPROVED BY | SHEET 1 OF 1 | SHEET SIZE A | SCALE 1/26 |
| DATE 5/25/2021 | | DATE | DATE | | |
| DRAWING NUMBER | | | | | REV A |
| 600-00026 | | | | | |