

# SAAF™ Front Access Housings

## TWO-STAGE TOTAL CLEAN AIR SYSTEMS

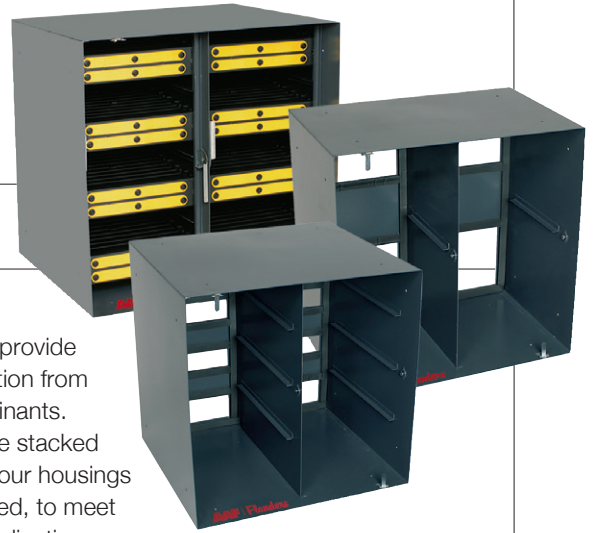

- Combines particulate filters and gas-phase cassettes to create total clean air solutions; removes both airborne particulate and gaseous contaminants
- Stand-alone system can be easily incorporated into new and existing air handling units; excellent for quick retrofit solutions
- Patented SAAF Seal sealing system design and manufacturing process. Patents covered under US 7,588,629 B2
- Energy efficient design reduces operating costs associated with air conditioning by allowing the maximum recirculation of tempered air

### Design and Construction

SAAF equipment is designed to provide the best solution for total protection from particulate and gaseous contaminants. AAF housings are designed to be stacked vertically into filter banks, up to four housings tall and as many wide as you need, to meet the specific demands of your application.

SAAF Front Access Housings are the premium solution for total air cleaning.

### SAAF™ Seal Provides Superior Integrity

AAF's patented SAAF Seal high integrity sealing system is a unique sealing system that prevents bypass of unfiltered air. Cassettes are held in place by a combination of channels and locking handles, which compress the cassettes firmly against the face gaskets.

This system is completely effective and simple to use, allowing quick and easy installation and replacement of cassettes. This system prevents bypass of contaminated air around the filter and ensures exceptional filter system efficiency.

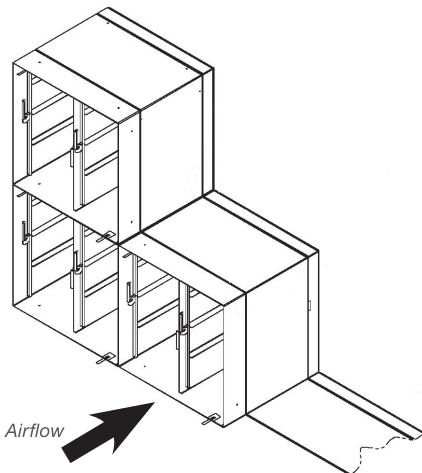

Typical Bank Construction – Individual or multiple SAAF™ Front Access Housings are assembled into complete filter banks as shown.

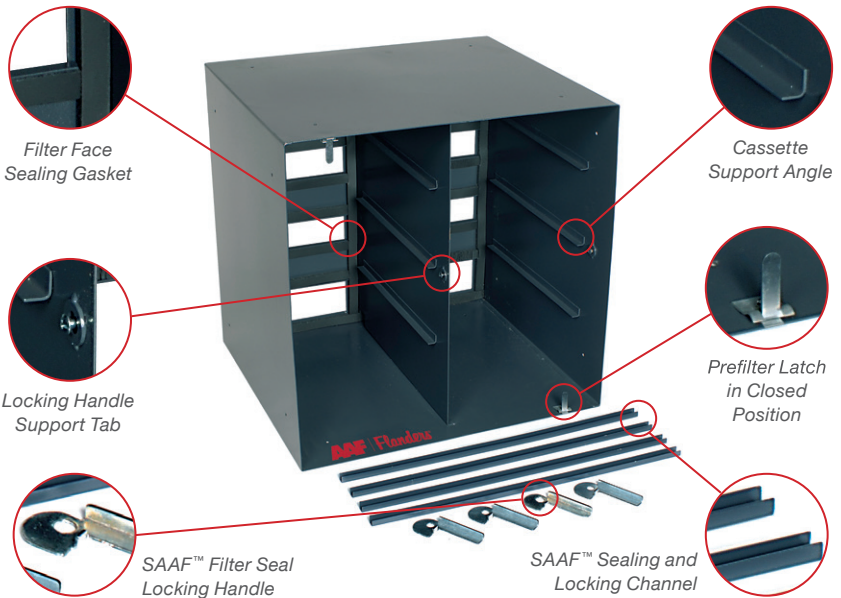

# SAAF™ Front Access Housings

## Value-Add Solution for Gas-Phase Air Filtration

SAAF Front Access Housings are designed to support SAAF chemical media filtration cassettes: Heavy Duty, Medium Duty, and Cleanroom Grade.



SAAF™ Cassettes perform and operate at optimum filtration efficiency, due to various patented features.

## Product Information

Model	Dimensions (H x W x D) (in.)	Rated Airflow (FPM / CFM)	Pressure Drop* (in. w.g.)
FAH-102-2P-MD	12" x 24" x 21½"	500/ 1000	0.31
FAH-201-2P-MD	24" x 12" x 21½"	500/ 1000	0.31
FAH-202-2P-MD	24" x 24" x 21½"	500/ 2000	0.31
FAH-102-2P-HD	12" x 24" x 15¾"	250 / 500	0.73
FAH-201-2P-HD	24" x 12" x 15¾"	250 / 500	0.73
FAH-202-2P-HD	24" x 24" x 15¾"	250/ 1000	0.73
FAH-201-2P-CG	24" x 12" x 15¾"	500/ 1000	0.47
FAH-202-2P-CG	24" x 24" x 15¾"	500/ 2000	0.47

\*Pressure drops shown are based on cassettes filled with AAF SAAFOxidant™ media. Pressure drops may differ slightly when alternative media are used.

## Built for Prefilter Option

SAAF Front Access Housings are designed to hold one 2" deep prefilter to prevent buildup of lint and dust on the face of the filtration cassette. Spring-loaded prefilter holding latches secure the prefilter into the housing frame. For best results, the MEGApleat® M9 filter is recommended.



BEST ← BETTER ← GOOD

MEGApleat® M9, PerfectPleat® HC M8 and PerfectPleat® SC M8 filters are ideal prefilters for SAAF™ Front Access Housings.

## Product Model Designations

The SAAF Front Access Housing model is designated as follows:

**FAH – 202 – 2P – MD**

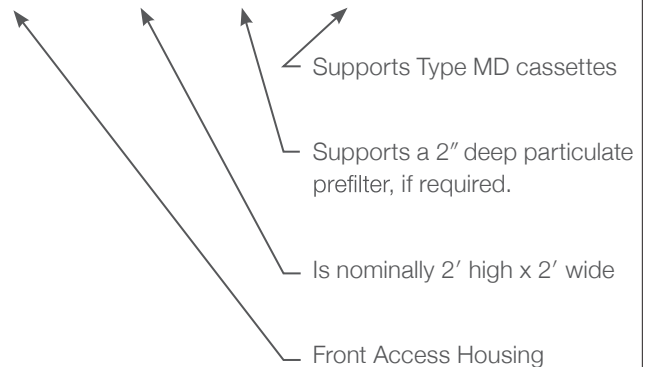

9920 Corporate Campus Drive, Suite 2200, Louisville, KY 40223-5690  
888.223.2003 Fax 888.223.6500 | aafintl.com

AAF has a policy of continuous product research and improvement. We reserve the right to change design and specifications without notice.

©2023 AAF International and its affiliated companies.

ISO Certified Firm

GPF-1-115E 11/23