











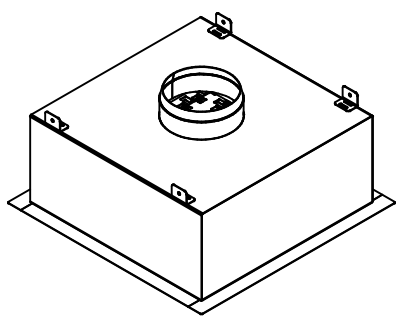
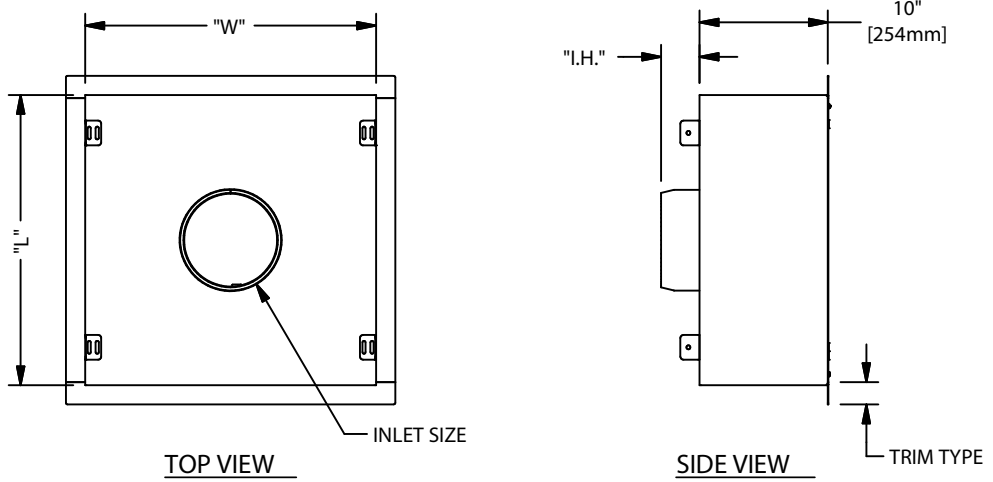

















HOOD SIZING		
W x L	DIMENSIONAL SIZES	METRIC DIMENSIONAL SIZE
2 x 2	22-11/16" x 22-11/16"	576.26 mm x 576.26 mm
2 x 3	22-11/16" x 34-11/16"	576.26 mm x 881.06 mm
2 x 4	22-11/16" x 46-11/16"	576.26 mm x 1185.86 mm

ITEM	HOOD SIZE	QTY
1		
2		
3		
4		
5		
6		
EX.	2 x 2	2

REV	ECN #	DESCRIPTION	BY	DATE
	20003	REMOVED GASKET AS A SEAL TYPE	MAK	1/6/20
	21006	REMOVED SWIRL TYPE GRILLES, REMOVED 316L MATERIAL TYPE, ADDED GRILLE OPTION FOR PERMANENT TRIM TYPE	MAK	1/11/21
	21293	ADDED CLEAN CEILING ANGLE - 2-3/8" AS AN OPTION, REMOVED 1X4 HOOD SIZE	RTW	8/18/21



ISOMETRIC VIEW
1-1/2" [38.1mm] FIELD INSTALLED
TRIM STYLE SHOWN

- MATERIAL**
 -  ALUMINUM
 -  304 STAINLESS STEEL
- SEAL TYPE**
 -  FLUID SEAL
- INLET SIZE**
 -  Ø 8" [203.2mm] ROUND
 -  Ø 10" [254mm] ROUND
 -  Ø 12" [304.8mm] ROUND
 -  Ø 14" [355.6mm] ROUND
 -  8" x 8" [203.2mm x 203.2mm] SQUARE
 -  10" x 10" [254mm x 254mm] SQUARE
 -  12" x 12" [304.8mm x 304.8mm] SQUARE
 -  14" x 14" [355.6mm x 355.6mm] SQUARE
- GRILLE TYPE**
 -  PERF SST *
 -  PERF PAINTED
- GRILLE OPTIONS**
 - ACORN NUTS
 - HINGED W/ 1/4 TURN FASTENERS & SAFETY CABLES
- MOUNTING TYPE**
 - HANGING TABS
 - MOUNTING PADS
 - CLEAN CEILING ANGLES - 2"
 - CLEAN CEILING ANGLES - 3"
 - CLEAN CEILING ANGLES - 2-3/8"
- TRIM TYPE**
 -  1/2" [12.7mm] PERMANENT (304 SST GRILLE)*
 -  1/2" [12.7mm] PERMANENT (316L GRILLE)*
 -  1/2" [12.7mm] FIELD INSTALLED (304 SST)
 -  1-1/2" [38.1mm] FIELD INSTALLED (304 SST)
 -  1/2" [12.7mm] FIELD INSTALLED (316L SST)
 -  1-1/2" [38.1mm] FIELD INSTALLED (316L SST)
- * HOOD BODY TO BE 304 SST
- INSULATION**
 -  NONE
 -  2" [50.8mm] FOILBACK
 -  3/4" [19mm] ARMAFLEX
- FINISH**
 -  NONE
 -  POWDER COATED
- FITTINGS**
 -  3/8" [8mm] FEMALE NPT
 -  3/8" [8mm] COLDER QUICK DISCONNECTS

APPLICABLE INLET SIZES			
HOOD SIZE	DUCT SIZE	ROUND ("I.H.")	SQUARE ("I.H.")
2 x 2	8" [203.2mm]/10" [254mm] ROUND/SQUARE	3" [76.2mm]	4" [101.6mm]
2 x 3	10" [254mm]/12" [304.8mm] ROUND/SQUARE	3" [76.2mm]	4" [101.6mm]
2 x 4	10" [254mm]/12" [304.8mm]/14" [355.6] ROUND/SQUARE	3" [76.2mm]	4" [101.6mm]

CUSTOMER APPROVAL
DRAWINGS MUST BE SIGNED IN ORDER TO PROCEED WITH PRODUCTION.
[] APPROVED [] APPROVED AS NOTED [] NOT APPROVED

SIGNATURE: _____ DATE: _____

COMMENTS: _____

QUOTE NO.: _____

UNLESS OTHERWISE SPECIFIED DIMENSIONS ARE IN INCHES TOLERANCES ARE:

FRACTIONS X/X	±1/8
DECIMALS X.XX	±0.13
DIAGONALS	±1/8

a member of DAIKIN group

TITLE: AstroHood S1

DRAWN BY: rwalston	CHECKED BY:	APPROVED BY:	SHEET: 1 OF 1	SHEET SIZE: A	SCALE: 1 / 15
DATE: 10/16/2019	DATE:	DATE:	DRAWING NUMBER: 600-00010		REV: C

THE INFORMATION CONTAINED ON THIS DRAWING IS PROPRIETARY TO AAF AND MAY NOT BE USED, REPRODUCED NOR TRANSMITTED TO OTHER PARTIES WITHOUT EXPRESSED WRITTEN CONSENT OF AAF.