

MODEL NUMBER EXAMPLE: AFUA-EC4R-600x1210-2-00-0-BS

MODEL NUMBER:

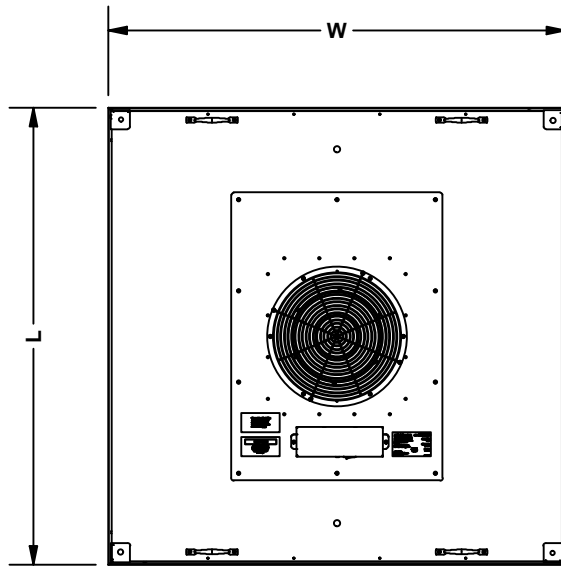

TOP VIEW

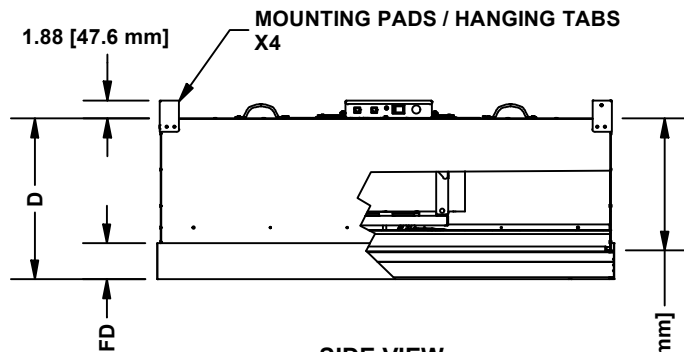

SIDE VIEW  
TOP SIDE SERVICEABLE SHOWN

\* FD- TSS FILTER DEPTH OR RSR ADAPTOR DEPTH.  
PLEASE NOTE HOUSING SITS INSIDE TSS/RSR FRAME

| FRAME STYLE | FD           | D             |
|-------------|--------------|---------------|
| TSS         | 3.73 [94.9]  | 16.75 [425.5] |
| RSR         | 4.73 [120.2] | 17.75 [451.0] |

**MATERIAL TYPE**

- AFUA = ALUMINUM
- AFUS = STAINLESS STEEL

**CONFIGURATION**  
CHOOSE SERVICEABLE SIDE

- EC = ELECTRONICALLY COMMUTATED MOTOR
- R = ROOM SIDE REPLACEABLE/ SERVICEABLE\*
- T = TOP SIDE SERVICEABLE\*\*

\* AEROSOL INJECTION AND PRESSURE PORTS PROVIDED STANDARD  
\*\* REQUIRES FILTER W/ CENTERBOARD PORT(S)  
FOR AEROSOL/PRESSURE MEASUREMENT

**STANDARD 1-1/2" T-BAR SIZES**

- 2X2 600x600 mm (23 5/8" x 23 5/8")
- 2X4 600x1210 mm (23 5/8" x 47 5/8")
- 4X4 1210x1210 mm (47 5/8" x 47 5/8")

**CUSTOM UNIT SIZE (WIDTH x LENGTH) mm**

WIDTH RANGE = 580-1220 mm  
LENGTH RANGE = 580-1220 mm



UNIT SIZE IS BASED ON TSS OR RSR FILTER FRAME TO GRID INTERFACE

**UNIT VOLTAGE**

- 1 = 100-130 VOLTAGE RANGE AC 50/60 HZ
- 2 = 200-277 VOLTAGE RANGE AC 50/60 HZ

**OPTIONS**

- 0 = NONE
- 1 = POWDER COATED HOUSING  
WHITE
- 2 = INSULATED HOUSING  
2" FOILBACK

- 0 = NONE
- A = ROUND DUCT COLLAR
- B = REC DUCT COLLAR /  
PRE-FILTER FRAME\*

\* REQUIRED FOR PREFILTER / OR AMC FILTRATION  
ORDERED SEPARATELY

| REV | ECN # | DESCRIPTION                                      | BY  | DATE    |
|-----|-------|--------------------------------------------------|-----|---------|
| △   |       | OPTIONS TERMINOLOGY CHANGE, WAS ALPHA CHARACTERS | JWH | 2/2/21  |
| △   | 21257 | ADD MODEL NUMBER BLANK                           | JWH | 7/15/21 |

**ACCESSORIES**

- 0 = NONE
- A = DOUBLE POLY BAGGED

**FILTER LOADING**

- T = TOP LOAD FILTER
  - TC = TOP LOAD WITH TEST PORT
  - BA\* = BOTTOM LOAD W/ ALUMINUM SCREEN
  - BS\* = BOTTOM LOAD W/ STAINLESS SCREEN
  - BP\* = BOTTOM LOAD W/ PAINTED SCREEN
- \* GRILLE SHIPS WITH RSR ADAPTOR

**FILTER OPTIONS**

- H13E = H13 / 99.99% @ 0.3 µm eFRM
- H14E = H14 / 99.995% @ MPPS eFRM
- U15E = U15 / 99.9995% @ MPPS ePTFE
- H13G = H13 / 99.99% @ 0.3 µm GLASS
- H14G = H14 / 99.995% @ MPPS GLASS
- U15G = U15 / 99.9995% @ MPPS GLASS

CUSTOMER APPROVAL  
DRAWINGS MUST BE SIGNED IN ORDER TO PROCEED WITH PRODUCTION.  
[ ] APPROVED [ ] APPROVED AS NOTED [ ] NOT APPROVED

SIGNATURE: \_\_\_\_\_ DATE: \_\_\_\_\_  
COMMENTS: \_\_\_\_\_

QUOTE NO.:

UNLESS OTHERWISE SPECIFIED  
DIMENSIONS ARE IN INCHES  
TOLERANCES ARE:



FRACTIONS X/X ±1/8  
DECIMALS X.XX ±0.13  
DIAGONALS ±1/8

TITLE: ASTROFAN

| DRAWN BY  | CHECKED BY | APPROVED BY | SHEET  | SHEET  | SCALE  |
|-----------|------------|-------------|--------|--------|--------|
| j.holland | S.TATE     | R.MIDGEFFE  | 1 OF 1 | SIZE A | 1 / 20 |

THE INFORMATION CONTAINED ON THIS DRAWING IS  
PROPRIETARY TO AAF AND MAY NOT BE USED,  
REPRODUCED NOR TRANSMITTED TO OTHER PARTIES  
WITHOUT EXPRESSED WRITTEN CONSENT OF AAF.

| DATE      | DATE      | DATE      | 1 OF 1 | SIZE A | 1 / 20 |
|-----------|-----------|-----------|--------|--------|--------|
| 1/13/2020 | 7/15/2021 | 7/15/2021 |        |        |        |

DRAWING NUMBER

600-00018

REV F