

Qty	Part Number	Actual Size H x W x D (in)	Media Area (SQ. FT.)	Rated Flow (CFM) @ 1" W.G.	Gasket
	3015302-001	24 x 24 x 11 1/2	431	2400	DOWNSTREAM ONLY
	3015302-002	24 x 12 x 11 1/2	215	1125	
	3015302-003	23 3/8 x 23 3/8 x 11 1/2	422	2270	
	3015302-004	23 3/8 x 11 3/8 x 11 1/2	211	1065	
	3015302-005	24 x 24 x 11 1/2	431	2400	DOWNSTREAM AND UPSTREAM
	3015302-006	24 x 12 x 11 1/2	215	1125	
	3015302-007	23 3/8 x 23 3/8 x 11 1/2	422	2270	
	3015302-008	23 3/8 x 11 3/8 x 11 1/2	211	1065	

NOTES:

- FRAME - CLEAR ANODIZED ALUMINUM EXTRUSION, ALLOY 6063-T5, ONE PIECE SIDES
- MEDIA PACK - MICRO GLASS FIBER WITH ACRYLIC BINDER PLEATS EVENLY SPACED USING ADHESIVE COATED FIBERGLASS STRING
- SEALANT - PHOSPHORUS FREE, FIRE RETARDANT POLYURETHANE
- GASKET - ONE PIECE URETHANE GASKET
- PERFORMANCE - MINIMUM EFFICIENCY OF 99.99% ON 0.3um PSL
- CERTIFICATIONS - UL-900 AND CAN4-S111, CLASS 2
- TOLERANCES - HEIGHT AND WIDTH: +0, -1/8 DEPTH: +1/16, -0
DIAGONALS WITHIN 1/8"
- MAXIMUM OPERATING TEMPERATURE - 158° F

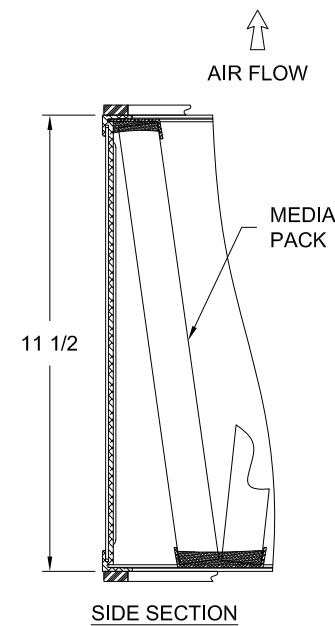
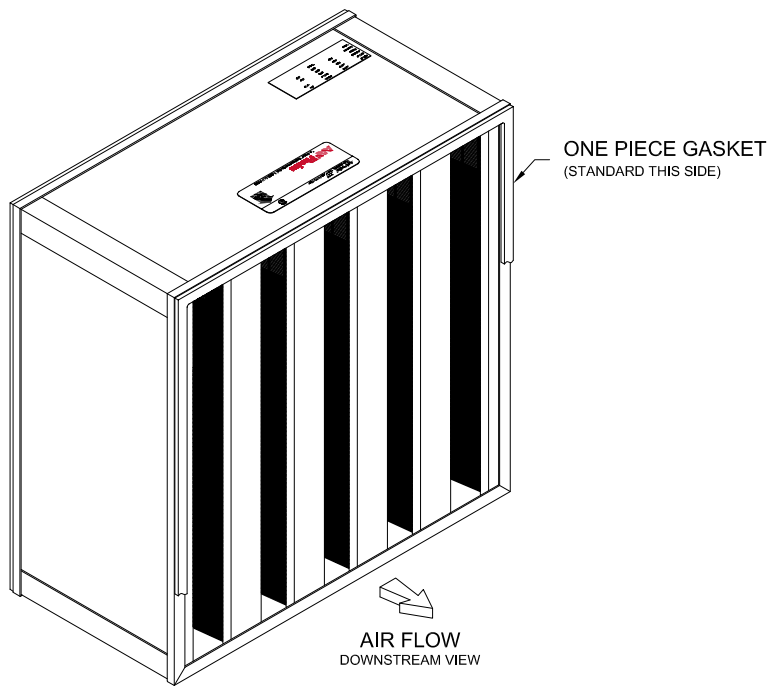
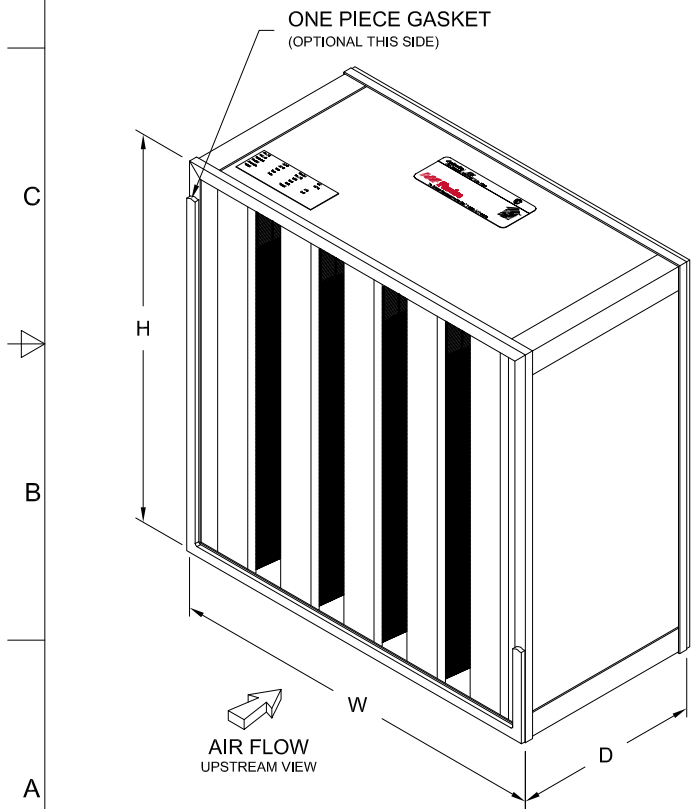

SALES/SUBMITTAL DRAWING

APPROVAL BLOCK

OKAY AS IS OKAY WITH REVISIONS NOTED

SIGNATURE: _____ DATE: _____

CONFIDENTIAL

©2015 AAF INTERNATIONAL. ALL RIGHTS RESERVED. THIS DRAWING AND THE INFORMATION CONTAINED OR REFERENCED HEREIN REMAINS THE EXCLUSIVE PROPERTY OF AAF INTERNATIONAL AND IS LOANED IN STRICT CONFIDENCE WITH THE UNDERSTANDING THAT IT WILL NOT BE REPRODUCED NOR USED FOR ANY PURPOSE EXCEPT FOR WHICH IT WAS LOANED. THIS DRAWING SHALL BE IMMEDIATELY RETURNED OR DESTROYED UPON REQUEST AND IS SUBJECT TO ALL OTHER TERMS AND CONDITIONS OF ANY WRITTEN AGREEMENT OR PURCHASE ORDER TO WHICH IT RELATES.



THIRD ANGLE PROJECTION

TOLERANCE UNLESS NOTED OTHERWISE
± 1/16" - ± 1/2"

MODELED BY: _____ DATE: 01NOV2019
 DRAWN BY: GAC DATE: 11NOV2019
 CHECKED BY: _____ DATE: 10NOV2019
 APPROVED BY: _____ DATE: _____

TITLE

**SUBMITTAL - ASTROCEL III
GASKET SEAL**

ESTIMATED WEIGHT:

DRAWING NUMBER
3172526

SECTION NUMBER: 105 SHEET SIZE: B

SHEET 1 OF 1 REV: -

4

3

2

1