

SPECIFICATIONS

1. THE HEIGHT AND WIDTH TOLERANCE IS +0/-1/8"; SQUARE WITHIN 1/8"
2. THE DEPTH TOLERANCE IS +1/16" / -0
3. THE FILTER RESISTANCE IS 1.0" W.G. MAXIMUM AT THE RATED FLOW
4. THE MAXIMUM TEMPERATURE EXPOSURE IS 500°F
5. THE MAXIMUM R.H. IS 100%
6. CLASSIFIED BY UNDERWRITERS LABORATORIES TO FLAMMABILITY ONLY UL 900.
7. IF SCAN TESTED, THE FILTER SHALL BE TESTED AT 90 FPM ±10% WITH AN APPROVED AEROSOL FOR LEAKS.

- FILTER HARDWARE - 0: NONE
- FILTER MEDIUM - 007: 99.97% AT 0.3 µm WATER RESISTANT GLASS
- PACK STYLE - F: 8" PUREFORM
 C: ALUMINUM SEPARATORS
- FRAME MATERIAL - 02: 16 GA T-409 SS
 03: 16 GA T-304 SS
 05: 0.063" ALUMINUM
 08: 16 GA GALVANEAL
- FRAME STYLE - 00: BOX STYLE
 03: TWO DOUBLE TURN FLANGES
- PACK SEALANT TEST METHOD - IE: HIGH TEMPERATURE SILICONE / DOP TEST (99.97%)
 SE: HIGH TEMPERATURE SILICONE / SCAN TEST (99.99%)
- GASKET MATERIAL LOCATION - 00: NONE
 31: COHRLASTIC SPONGE UPSTREAM
 32: COHRLASTIC SPONGE DOWNSTREAM
 33: COHRLASTIC SPONGE BOTH SIDES
- FACEGUARD MATERIAL LOCATION - 00: NONE
 21: STAINLESS STL. UPSTREAM
 22: STAINLESS STL. DOWNSTREAM
 23: STAINLESS STL. BOTH SIDES
- SIZE CODE - **GG-F EXAMPLE SEE CHART**



| SIZE DESIGNATORS & RATED FLOW @ 1.0" W.G. | | | | |
|---|---------|---------|---------|------------------|
| SIZE CODE | HEIGHT | WIDTH | DEPTH | RATED FLOW (CFM) |
| CC-F | 12" | 12" | 11 1/2" | 205 |
| YU-F | 23 3/8" | 11 3/8" | 11 1/2" | 425 |
| GC-F | 24" | 12" | 11 1/2" | 455 |
| GE-F | 24" | 18" | 11 1/2" | 725 |
| YY-F | 23 3/8" | 23 3/8" | 11 1/2" | 945 |
| GG-F | 24" | 24" | 11 1/2" | 1000 |
| GN-F | 24" | 30" | 11 1/2" | 1275 |

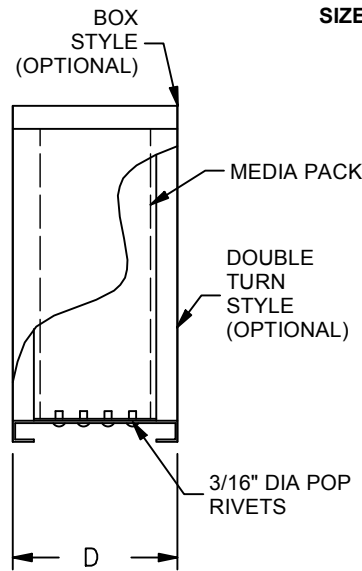
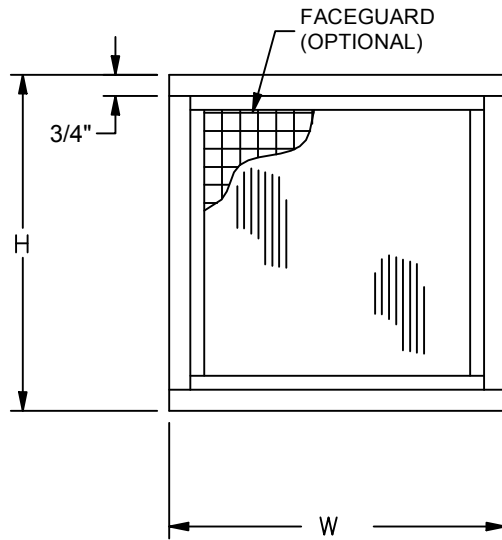

| | | | | | |
|---|----------------------|---|----------------------------------|--------------------|--------------|
| CUSTOMER APPROVAL DRAWINGS MUST BE SIGNED IN ORDER TO PROCEED WITH PRODUCTION. [] APPROVED [] APPROVED AS NOTED [] NOT APPROVED - RESUBMIT | | | | | |
| SIGNATURE: _____ | | DATE: _____ | | | |
| COMMENTS: _____ | | | | | |
| QUOTE NO.: _____ | | | | | |
| UNLESS OTHERWISE SPECIFIED DIMENSIONS ARE IN INCHES TOLERANCES ARE: | | | | | |
| FRACTIONS X/X ±1/8 DECIMALS X.XX ±0.13 DIAGONALS ±1/8 | | TITLE: ALPHA HT, METAL FRAME, GASKET SEAL | | | |
| DRAWN BY jholland | CHECKED BY S.TATE | APPROVED BY M.RENN | SHEET 1 OF 1 | SHEET SIZE A | SCALE NTS |
| DATE 8/12/2021 | DATE 9/8/2021 | DATE 9/21/2021 | DRAWING NUMBER 600-00028-0009 | | |
| THE INFORMATION CONTAINED ON THIS DRAWING IS PROPRIETARY TO AAF AND MAY NOT BE USED, REPRODUCED OR TRANSMITTED TO OTHER PARTIES WITHOUT EXPRESSED WRITTEN CONSENT OF AAF. | | | | | REV A |